

U5

DRAINAGE PUMPS

- Cooling jacket for motor housing
- Low level pumping by detachable strainer base
- Flushing device
- Variable discharge branch with closable ventilation
- Run dry protection
- 10/20 mm free passage with EIP technology
- Moisture sealed cable inlet



DESCRIPTION

The U5K(S) is an extremely powerful and versatile centrifugal submersible pump for both stationary and portable use. The pump is suitable for faecal-free wastewater with solids up to 10 mm particle size. Thanks to the removable strainer base, it is possible to increase the free passage to 20 mm.

Stationary in a basement chamber or a collecting tank, with an automatic switch attached, the U5KS handles all dirty water arising from domestic drainage sources such as washing machines, dishwashers, washstands, etc. Deposit accumulation in the reservoirs and chambers is reduced to a minimum by means of a flushing device.

The guide rail system GR 32 offers all the advantages of fast and easy maintenance. If the sump or tank runs dry temporarily, the pump can be vented by providing a drill-hole in the spiral housing.

The U5K can be used as a portable unit for dealing with dirty water from garden ponds, flooded cellars or discharge chambers in laundry rooms or storage rooms. Thanks to its shallow, built-in suction system, it can reduce residual water level to no more than a few millimeters.

If submersible pumps are used outdoors, only a pump with 10 m cable without extension cable may be used in accordance with VDE Regulation 0100. For construction sites and garden ponds, a H07-type cable must be used.

PERFORMANCE

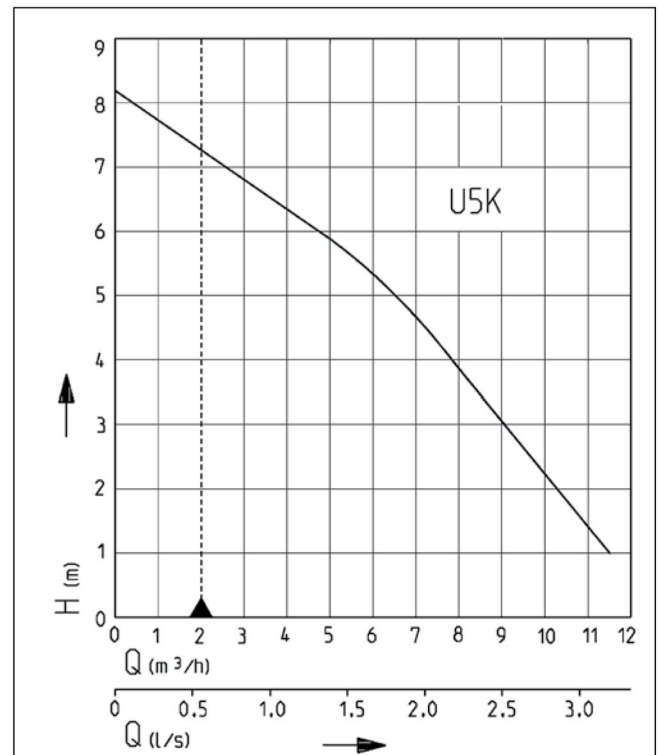

Type	Delivery head H [m]	1	2	3	4	5	6	7
U5K/U5KS	Flow rate Q [m³/h]	11.5	10.5	9.0	7.5	6.5	4.5	2.5

We reserve the right to change specifications without notice. Pump performance is subject to ISO 9906 tolerances

The minimum flow velocity in the pressure piping must be 0.7 m/s according to EN 12056. This data is represented in the performance curve as a limit of application.



U5

DRAINAGE PUMPS

SCOPE OF SUPPLY

Pump ready for connection acc. to EN 12050 with 90°, 1/4" female connection elbow, cable and safety plug, S model with automatic level float switch.

The pump is delivered fitted with a strainer base which can be swapped for any of the accompanying pedestals in cases where a 20 mm clear passage is required.

MECHANICAL DATA

Pump	Vertical single-stage	Run dry protection	Yes
Free passage	20 mm	Shaft	Stainless steel
Bearing	Ball bearings, grease-lubricated	Impeller	Vortex impeller, GFK
Seal on motor side	Rotary shaft seal	Motor housing	Stainless steel
Oil chamber	Yes	Pump housing	GRP
Seal on medium side	2-fold rotary shaft seals	Submersible	Yes
		Pressure outlet	1 1/4"

ELECTRICAL DATA

Voltage	1/N/PE~230 V	Insulation class	B
Motor rating P1	0.52 kW	Winding thermostat	Yes
Motor rating P2	0.38 kW	Motor protection	Integrated
Current	2.3 A	Plug	Safety
Type of enclosure	IP 68		

U5

Type	Code No.	Power line	Wires	Weight
Without level control				
U5K, 10 m cable	JP09386	10m H05RN-F	3G0,75	4.7 kg
With built-in level control				
U5KS, 4 m cable	JP09387	4m H05RN-F	3G0,75	4.5 kg
U5KS, 10 m cable	JP09417	10m H07RN-F	3G1,0	5.4 kg

Dimensions and switching points U5KS (mm)

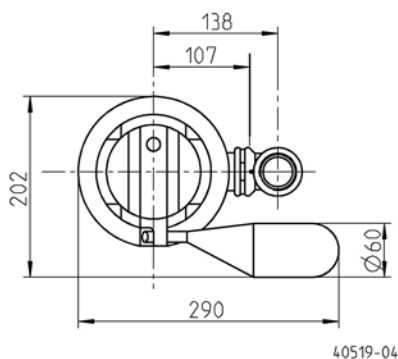
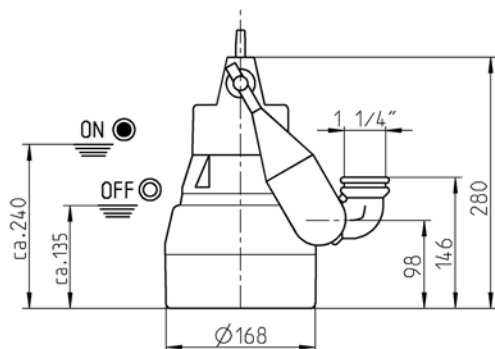

Dimensions and switching points special float switch (mm)

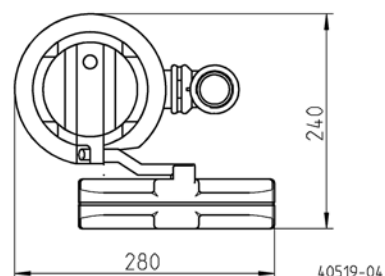
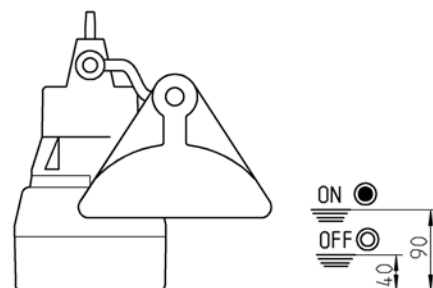

U5

DRAINAGE PUMPS

Dimensions and switching points float switch (mm)

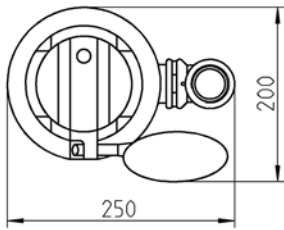
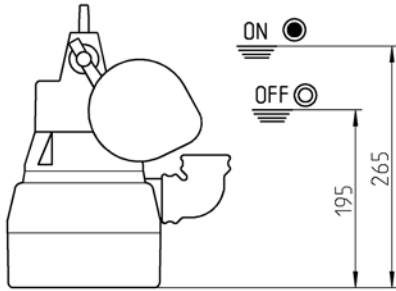

40519-04

Dimensions and switching points GR 32 (mm)

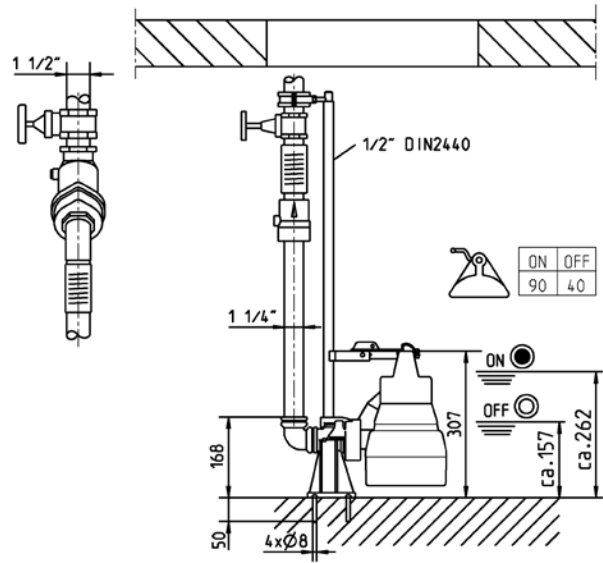

ON	OFF
90	40

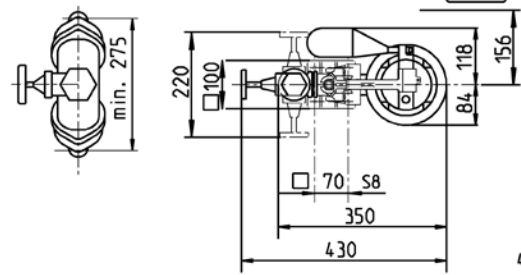

40523-05

U5

DRAINAGE PUMPS

Example of single pump installation with GR

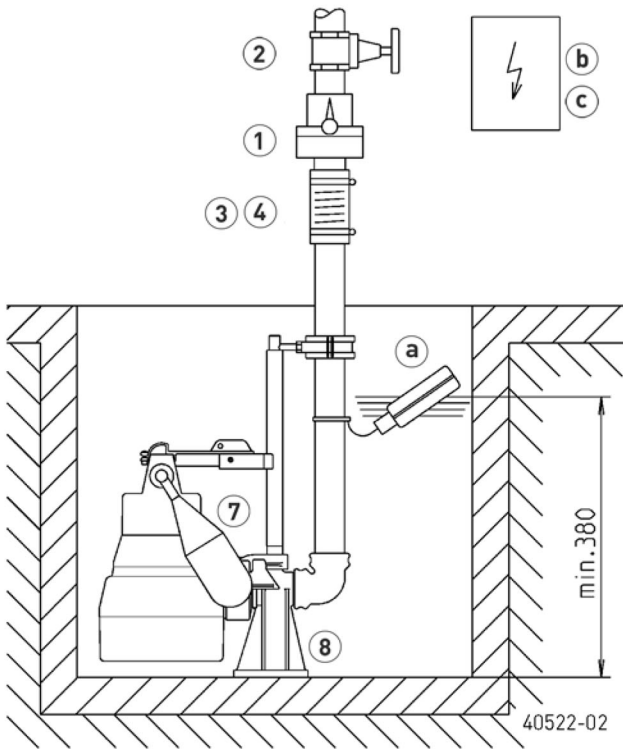

Single unit with GR: sump area min. 40x50 cm or Ø 50 cm
 Single unit without GR: sump area min. 40x40 cm or Ø 40 cm
 Duplex unit with GR: sump area min. 50x50 cm, Ø 80 cm
 Duplex unit without GR: sump area min. 50x50, Ø 55 cm

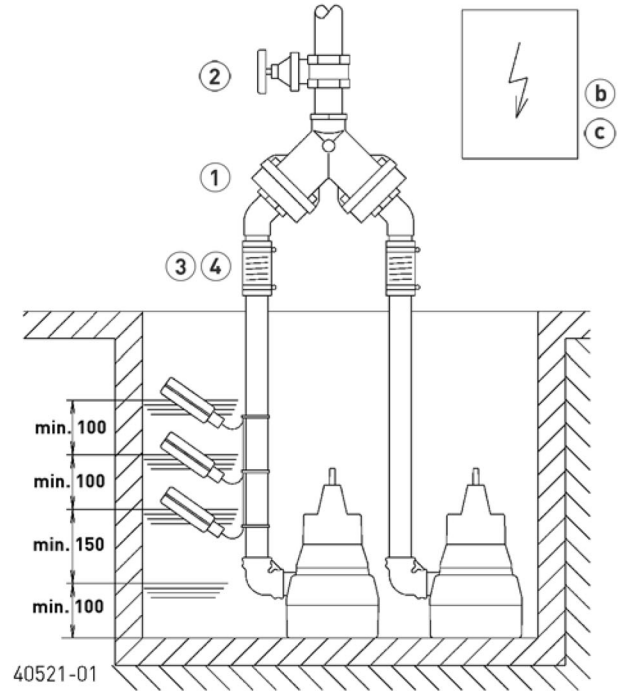

In case of installation beneath the backpressure level the pressure tube must be taken in a

Example of duplex installation



loop over the local backup level acc. to EN 12056. Besides, it must be secured with an EN 12050-4-proofed swing-type check valve. Additionally we recommend an alarm system. In accordance with EN 12056-4 section 5.1, it has a built-in automatic spare pump or a double attachment included, which ensures that sewage drainage is not interrupted. Suspend control unit in a dry room

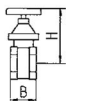
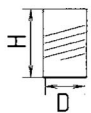





MECHANICAL ACCESSORY

				Code No.
	1 Swing-type check valve			
	R32 EN 12050-4	1/4" (DN 32), PN 4	90x90 (HxB)	JP09739
	DR 40 EN 12050-4	1/2" (DN 40), PN 4	200x280 (HxB)	JP09155
	2 Stop valve			
		1/4" (DN 32), PN 16	110x60 (HxB)	JP44785
		brass, 1/2" (DN 40), PN 16	125x60 (HxB)	JP44786
	3 Elastic connection			
		1/4" (DN 32), PN 3	100x42 (HxD)	JP44773
	4 Hose band clamp			
		1/4"		JP44765
	5 Hose coupling			
	Hose coupling	1/4" (DN 32) brass, for transportable use		JP00327
	Coupling Storz C	1 1/4" male thread		JP44780
	Coupling wrench			JP25708
	House connection	1/4" - 38/32/25		JP44209

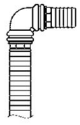



U5

DRAINAGE PUMPS

MECHANICAL ACCESSORY

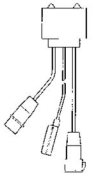
			Code No.
	6 Hose set	1 1/4" (DN32), 15 m PVC hose c/w elbow	JP43550
	7 Special float	for lower switching points (U5 and U6)	JP44207
		for narrow chambers (mind. 30x30 od Ø30 cm)	JP40856
	Float fixation	for continuous pump operation	JP42175
	8 Guide rail system	GR 32	JP44000
	Support for guide rail extension	ex 2 m sump depth, per m 1 piece	JP28314
	9 Connection kit	DN 32, with telescopic pressure pipe 30-90 cm	JP44609

ELECTRICAL ACCESSORY

			Code No.
	a Alarm unit		
	AG3	subm. ball contact switch, mains dependent, potential-free contact, 3 m cable	JP44891
	AG10	subm. ball contact switch, mains dependent, potential-free contact, 9.5 m cable	JP44892
	Washing machine stop		
	AW3	subm. ball contact switch, mains dependent, 3 m cable	JP44895
	b Control for single units		
	Control unit NE 1	230 V, subm. ball contact switch 3.0 m	JP16710
	Control unit NE 1A	230 V, subm. ball contact switch 3.0 m, alarm	JP16714
	Control unit NE 2	230 V, subm. ball contact switch 9.5 m	JP16711
	Control unit NE 2A	230 V, subm. ball contact switch 9.5 m, alarm	JP16715
	Control for duplex units		
	Control unit BD 00 E	230 V, for pumps U3-U6, US 62-105, UV 300, 08/2 ME	JP45735
	Control unit HIGHLOGO 2-00 E	230 V	JP47996
	Level control		
	Subm. switch pack B	3 subm. ball contact switch with 9.5 m and fixing devices	JP16725
	Subm. switch pack BmG	3 subm. ball contact switch with 9.5 m and counterweight	JP16726
	Weight	to stabilize the subm. ball contact switch	JP44803
	c Rechargeable battery	for mains independent alarm	JP44850
	d Smart Home	FTJP radio transmitter	JP47209

U5

DRAINAGE PUMPS